

IRIS INSTRUMENTS

NUMIS^{Poly}

multi channel
MAGNETIC RESONANCE
SOUNDING SYSTEM FOR
**DIRECT DETECTION
OF GROUNDWATER**

DOWN TO 150 m DEPTH

water content
permeability estimate

GROUNDWATER RESOURCES EVALUATION:

Determination of water level and quantity
Lateral extension of an aquifer layer
Selection of the best place to drill
Prediction of yield, after calibration

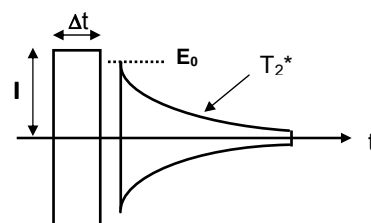

E_0 : Initial amplitude of signal (nV)
Proportional to the **water content** (%)
 T_2^* : Decay time constant of signal (ms)
Related to the **mean pore size** (permeability)
 $I \cdot \Delta t$: Excitation pulse moment (A.ms)
Related to the **investigation depth** (m)

MAGNETIC RESONANCE SOUNDING SYSTEM

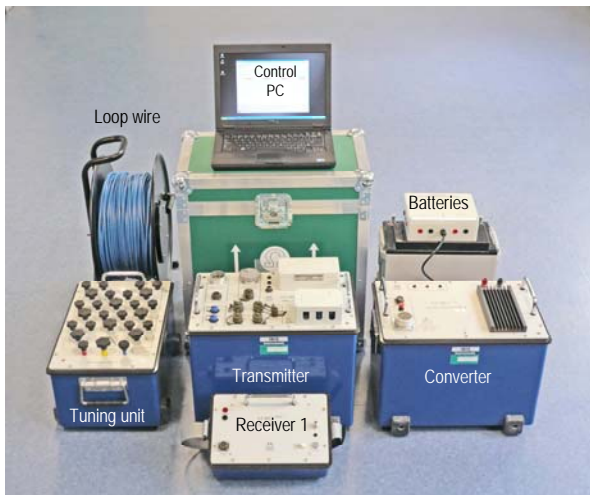

NUMIS^{Poly} is a modular MRS equipment consisting of :

- a transmitter unit for pulse generation
- up to four receivers units for signal measurement
- a PC computer for the control of the whole system and for data processing and interpretation
- 2 converter units powered by two 12 V batteries each
- 2 tuning units for optimizing the excitation energy
- wire for transmitting and receiving loop coils

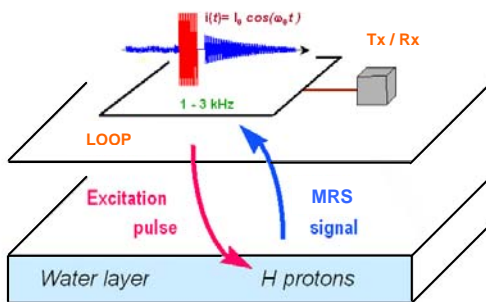

The Magnetic Resonance Sounding method (MRS):

The MRS is the only **non-invasive** method which directly studies groundwater reservoirs from surface measurements:

A pulse of current, at a given frequency, is transmitted into a loop.

The signal produced in return by the H protons (water molecules) is measured within the same loop.

How to carry out a Magnetic Resonance Sounding ?

- 1- **Measure the Earth magnetic field** to know the frequency to apply
- 2- **Transmit a pulse of current** into a loop, at this frequency
- 3- **Measure the amplitude** of the water MR signal (\approx porosity)
- 4- **Measure the time constant** of the signal (\approx mean pore size)
- 5- **Change the pulse intensity** to modify the depth of investigation
- 6- **Use the inversion program** to get the porosity versus the depth

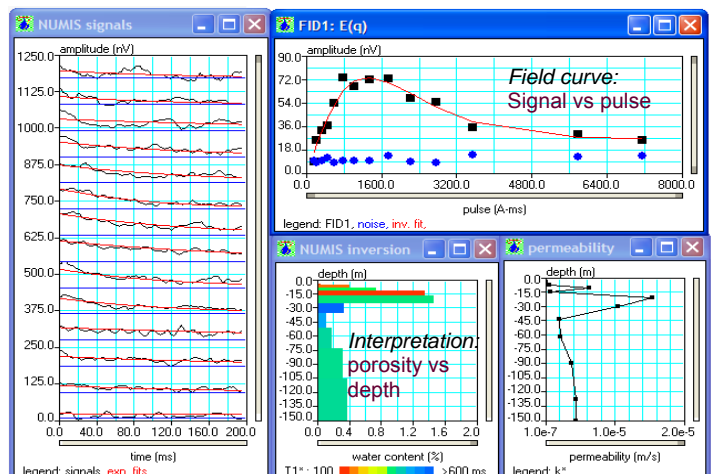

NUMIS^{Poly} MRS equipment

NUMIS^{Poly} MAIN FEATURES

- NUMIS^{Poly} is a modular multi channel MRS equipment designed with units weighting 25 kg or less, making it man portable.
- The transmitter unit produces pulses at the Larmor frequency
- The receiver units (up to 4) measure the MRS signal and the noise, after filtering, amplification and analog to digital conversion.
- The PC computer receives raw data, then processes, displays and stores them (including time series) for further interpretation
- The two DC / DC converter units are required for a maximum investigation depth of 150 m), to energize the 150 m side square loop (600 m total length). However, if an investigation of 100 m is sufficient, one converter unit only is required with a 100 m side square loop (400 m total length)
With one only converter, just the **transverse time constant (T_2^*)** is measured, while with two converters, the transverse and the **longitudinal (T_1) time constants** are measured; T_1 offers a better estimation of the permeability than T_2^*
- The two tuning units must be used at lower magnetic latitudes (for an Earth's field lower than 31 000 nT with the 150 m side square loop, or 37 000 nT with the 100 m side square loop), while one tuning unit only is needed at medium and higher latitudes
- The receivers 2 to 4 can be used for remote reference purposes (signal to noise enhancement) or 2D acquisition

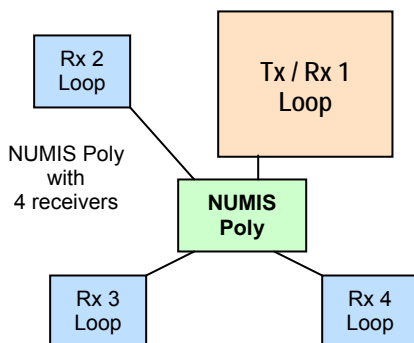

NUMIS Poly
4 channel MRS system

- signal to noise ratio enhancement through remote reference techniques with the simultaneous acquisition of various receiving channels and cross spectra analysis
- 2D acquisition on the four receiving channels

NUMIS Poly CONFIGURATIONS			
Investigation depth	Converter number	Tx Loop dimensions	Receiver number
100m	one	100 x 100 m	1 to 4
150m	two	150 x 150 m	1 to 4



IRIS Instruments, 1 avenue Buffon, BP 6007, 45060 ORLEANS Cedex 2, FRANCE
Tel: + 33 2 38 63 81 00 Fax: + 33 2 38 63 81 82 E-mail: info@iris-instruments.com Web: iris-instruments.com

NUMIS^{Poly}

TECHNICAL SPECIFICATIONS

DC/DC CONVERTER UNIT

- power supply: two 12 V batteries (65 Ah each)
- 12 hours reading autonomy
- capacitance: 84 mF
- outputs: ± 430 V DC; 0.5 A
- two converters may be used in parallel
- dimensions: 43 x 30 x 41 cm; weight: 23 kg

TRANSMITTER (Tx) UNIT

- supplied by one or two DC/DC converters
- frequency range: 0.8 to 3 kHz
- maximum outputs: 4000 V, 600 A
- pulse amplitude and duration: programmable
- pulse moment: 100 to 24 000 A.ms (loop and frequency dependant) for 40 ms standard pulse
- dimensions: 43 x 30 x 44 cm; weight: 23 kg

REVEIVER UNIT (up to 4 units: Rx1 to Rx4)

- band pass filter width: 150 Hz; automatic range
- noise: less than 10 nV / sqrt(Hz)
- A/D converter: 16 bits
- sampling frequency: up to 76.8 kHz
- raw data (time series) storage for post processing
- calibration procedure for phase reference
- measurement of T_2^* (with one converter) and of T_2^* and T_1 (with two converters)
- 24 hours autonomy
- dimensions: 30 x 21 x 21 cm; weight: 4 kg

TUNING UNIT

- tuning of the loop to the Larmor precession frequency by capacitors
- capacitance of 6 to 30 μ F with one tuning unit and up to 60 μ F with two tuning units
- dimensions: 43 x 30 x 34 cm; weight: 20 kg

TRANSMITTING / RECEIVING LOOP

- wire for Tx & Rx1 loops: 100 m, 10 mm² section
- 4 reels for 100 m investigation, 0.7 ohm, 0.8 mH
- 6 reels for 150 m investigation, 1.0 ohm, 1.2 mH
- other Tx & Rx1 loop configuration: on request
- loops for Rx2 to 4: 2 reels 200m; 1 reel 7 x 40m
- cable between Rx2 to Rx4 and Transmitter: 100m

PC COMPUTER

- control of the whole system: converter, transmitter, receivers; data storage
- data processing: DFT and cross correlation
- data interpretation: 1D inversion

SQUARE (standard) and EIGHT (noise reduction) loop shapes for MRS soundings

